

DRAINAGE PRODUCTS & WASTE WATER ACCESS CHAMBERS

LIST PRICE PAGES

April 8, 2024



Fittings and flexible couplings can be added to items in this price page for shipment from Fargo.

G

P

K

DISCOUNTS: Contact your GPK Sales Rep or Factory Salesman.

FREIGHT: Freight is paid on orders of \$3,000.00 net to points within the Continental U.S. only. Shipments to Hawaii, Alaska, and overseas points will be prepaid to point of embarkment only. All custom charges and other duties are the responsibility of the purchaser. If partial shipments are needed on a rush basis, shipped against a freight allowed order, it will be shipped immediately on a F.O.B. Fargo basis. All orders that do not qualify for prepaid freight will be shipped collect.

RETURNS: Custom made drainage products are non-cancelable non-returnable. All other returns must be authorized by the factory. Normal terms are 25% restocking charge and return freight paid.

SPECIAL FITTINGS: Are available upon request. Once production has started on special items, cancellations will not be permitted. Special fittings are non-returnable.

PRICE PAGE IMAGES: Are not exact images of the finished product.

PRICES SUBJECT TO CHANGE WITHOUT NOTICE.
For Warranty, complete Terms and Conditions of Sale/ Shipment and use, see the inside back cover of this booklet or the back of your invoice.

1601 43rd St. N. ✦ Fargo, North Dakota ✦ 58102
Phone: 701-277-3225 ✦ Toll Free: 1-800-437-4670
Fax: 701-277-9286 or 1-800-822-6989
Visit our website at www.gpk-fargo.com

Drain Basins

Inline Drains

Riser Extensions,

Waste Water
Access Chambers

**ADD
GPK FITTINGS
AND
INDIANA SEAL
FLEXIBLE COUPLINGS
TO MEET THE
\$3000.00 FFA**

1601 43rd St. N. Fargo, North Dakota 58102
Phone: 701-277-3225 Toll Free: 1-800-437-4670
Fax: 701-277-9286 or 1-800-822-6989
Visit our website at www.gpk-fargo.com



DRAIN BASINS

(With Grates)

www.gpk-fargo.com

(For Submittal Information and dimensional data visit our website)

Drain Basin with Gate:									
Round Drop in, Round with frame, Square Hinged, and Domed									
BASIN HEIGHTS:		5' or Less				10' or Less			
Product Description	Outlet Sizes	ROUND GRATES AND 12" & 15" SQUARE HINGED		DOMED GRATES & SOLID		ROUND GRATES AND 12" & 15" SQUARE HINGED		DOMED GRATES & SOLID	
		Part No	List Price	Part No	List Price	Part No	List Price	Part No	List Price
8" Drain Basin	4"-8"	DB0508R	440.09	DB0508D	479.97	DB1008R	534.50	DB1008D	574.40
10" Drain Basin	4"-10"	DB0510R	603.64	DB0510D	650.20	DB1010R	743.26	DB1010D	789.79
12" Drain Basin	4"-12"	DB0512X	884.18	DB0512D	951.99	DB1012X	1,138.15	DB1012D	1,205.96
15" Drain Basin	4"-15"	DB0515X	1,265.79	DB0515D	1,400.07	DB1015X	1,445.30	DB1015D	1,579.57
18" Drain Basin	4"-18"	DB0518R	1,483.83	DB0518D	1,729.83	DB1018R	1,668.65	DB1018D	1,914.64
24" Drain Basin	4"-24"	DB0524R	1,861.47	DB0524D	2,161.94	DB1024R	2,083.50	DB1024D	2,384.00
30" Drain Basin	4"-30"	DB0530R	2,999.60	DB0530D	3,593.95	DB1030R	3,659.09	DB1030D	4,253.43

X - Denotes grate type - Specify R for Round or S for Square Hinged. Square Hinged available in 12" or 15" sizes only.
For Round and Domed grates with frame add F to the end of the part number

Drain Basin with Gate:									
Traffic Rated Gate & Curb Inlet Gate									
BASIN HEIGHTS:		5' or Less				10' or Less			
Product Description	Outlet Sizes	Traffic Rated Gate		Curb Inlet Gate		Traffic Rated Gate		Curb Inlet Gate	
		Part No	List Price	Part No	List Price	Part No	List Price	Part No	List Price
2X2 Square									
12" Drain Basin	4"-12"	DB0512TS	959.98	DB0512CS	3,116.69	DB1012TS	1,215.28	DB1012CS	3,227.64
15" Drain Basin	4"-15"	DB0515TS	1,340.26	DB0515CS	3,255.42	DB1015TS	1,506.45	DB1015CS	3,490.12
18" Drain Basin	4"-18"	DB0518TS	1,564.95	DB0518CS	3,490.12	DB1018TS	1,749.76	DB1018CS	3,751.42
24" Drain Basin	4"-24"	DB0524TS	1,939.92	DB0524CS	3,781.48	DB1024TS	2,161.96	DB1024CS	4,098.28
30" Drain Basin	4"-30"	DB0530TS	3,076.71	DB0530CS	4,618.57	DB1030TS	3,736.24	DB1030CS	4,882.17
2X3 Rectangle									
18" Drain Basin	4"-18"	DB0518TR	1,644.74	DB0518CR	2,847.20	DB1018TR	1,828.22	DB1018CR	3,200.86
24" Drain Basin	4"-24"	DB0524TR	2,019.69	DB0524CR	3,244.75	DB1024TR	2,239.08	DB1024CR	3,650.29
30" Drain Basin	4"-30"	DB0530TR	3,152.49	DB0530CR	4,178.14	DB1030TR	3,819.97	DB1030CR	4,414.81

TS - Traffic Rated Square
TR - Traffic Rated Rectangle
CS - Curb Inlet Square
CR - Curb Inlet Rectangle



\$75.00 net surcharge for Round and Square Hinged locking grates.

\$175.00 net surcharge for 2x2' Square and 2x3' Rectangle locking grates.



DRAIN BASINS

(No Grates)

www.gpk-fargo.com
 (For Submittal Information and dimensional data visit our website)

Drain Basins

Drain Basin without Grate					
BASIN HEIGHTS:		5' OR LESS		10' OR LESS	
Product Description	Outlet Sizes	WITHOUT GRATE		WITHOUT GRATE	
		Part No	List Price	Part No	List Price
8" Drain Basin	4"-8"	DB0508	378.95	DB1008	472.01
10" Drain Basin	4"-10"	DB0510	499.91	DB1010	647.53
12" Drain Basin	4"-12"	DB0512	647.53	DB1012	878.86
15" Drain Basin	4"-15"	DB0515	936.06	DB1015	1,199.32
18" Drain Basin	4"-18"	DB0518	1,023.80	DB1018	1,315.01
24" Drain Basin	4"-24"	DB0524	1,401.41	DB1024	1,752.41
30" Drain Basin	4"-30"	DB0530	2,277.61	DB1030	2,922.49



- * Outlets available for Corrugated HDPE, PSM, IPS, C900 and Profile Pipe.
- * Outlet gaskets are included on all Drains.
- * Drain Basins are to be made of PVC PSM/PS46.



Drain Basin Order/Quote Form

www.gpk-fargo.com

(For Submittal Information and dimensional data visit our website)

PO#: _____ Date: _____ Quote#: _____

Sale Order _____ Job Name & Location: _____
(To be Assigned by GPK)

Company: _____

Contact: _____

Address: _____

City: _____ State: _____ Zip: _____

Phone: _____ Fax: _____ Email: _____

Signature: _____

Drain Basin Size: _____ Drain Basin Height (A): _____ ft.

Grate Type: _____ Grate Style: _____

Additional Height for Field Cut (E): _____ ft.

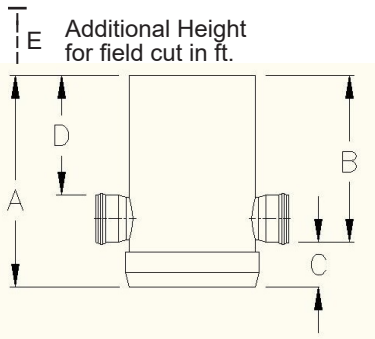
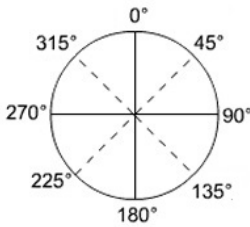

**Minimum Top of Outlet to Top of Basin (D)
Minimum Sump Depths (C)**

Basin Size	Minimum
8"	6"
10"	6"
12"	6"
15"	6"
18"	6"
24"	8"
30"	10"

* D & C Dimensions are the Same

Notes

Outlet #	Size (Inches)	Outlet Type	Pipe Manufacturer	Position (Degrees)	Invert Height (B)
1					
2					
3					
4					
5					
6					

Refer to Chart for Minimum Angle Between Outlets.

Outlet Types

YG	C900 Gasketed	JM	JM Eagle Corrugated
YH	C900 Solvent Weld	PR	Prinsco Corrugated
PG	PSM Gasketed	UR	Ultra Rib
PH	PSM Solvent Weld	UC	Ultra Corr
IG	IPS Gasketed	C2	Corr21
IH	IPS Solvent Weld	P2	Pro21
AD	ADS Corrugated	HG	Heavywall Sewer G
O	Other	HH	Heavywall Sewer SW

Grate Types

Round W/Frame (8" - 30")
Drop In (8" - 30")
Domed (8" - 30")
Domed W/Frame
Square Hinged (12" & 15")
Curb Inlet 2'x3'
Standard, Diagonal, High Flow

Grate Style

H-20
Solid 8" - 10"
Solid With Frame 12" - 30"

Note: Basins Over 8' Use Coupling
 * All Drain Basins are Non-Returnable and Non-Cancelable Upon Beginning of Production.
 * All Joints are Water Tight.
 * A dimension is overall height without grate.
 * Drain Basins are to be made of PVC PSM/PS46.

1601 43rd Street North • Fargo, ND 58102
 Phone: 701-277-3225 Toll Free: 800-437-4670
 Fax: 701-277-9286 or 800-822-6989



INLINE DRAINS

www.gpk-fargo.com

(For Submittal Information and dimensional data visit our website)



Inline Drains

Inline Drains							
Product Description	Outlet Sizes	With Grate				Without Grate	
		ROUND GRATES AND 12" & 15" SQUARE HINGED		DOMED GRATES		WITHOUT GRATE	
		Part No	List Price	Part No	List Price	Part No	List Price
8" Inline Drain	4"-8"	IDTT08-SSR	134.29	IDTT08-SSD	174.86	IDTT08-SS	87.75
10" Inline Drain	4"-10"	IDTT10-SSR	168.86	IDTT10-SSD	215.41	IDTT10-SS	114.35
12" Inline Drain	4"-12"	IDTT12-SSX	537.17	IDTT12-SSD	604.99	IDTT12-SS	378.95
15" Inline Drain	4"-15"	IDTT15-SSX	634.24	IDTT15-SSD	768.53	IDTT15-SS	409.52
18" Inline Drain	4"-18"	IDTT18-SSR	769.85	IDTT18-SSD	1,015.85	IDTT18-SS	497.28
24" Inline Drain	4"-24"	IDTT24-SSR	1,434.67	IDTT24-SSD	1,735.14	IDTT24-SS	1,010.65
30" Inline Drain	4"-30"	IDTT30-SSR	1,733.83	IDTT30-SSD	2,328.15	IDTT30-SS	1,239.23

* X Denotes grate type - Specify R for Round or S for Square Hinged.
Square Hinged available in 12" or 15" sizes only.

* TT Denotes Outlet Type - SS Denotes Outlet Size
Ex. For a 10" Inline Drain with an 8" PSM gasketed outlet
the part number would be IDPG10-08R

\$75.00 net surcharge for locking grates.
(Round and Square Hinged)

Outlet Types

YG	C900 Gasketed	JM	JM Eagle Corrugated
YH	C900 Solvent Weld	PR	Prinsco Corrugated
PG	PSM Gasketed	UR	Ultra Rib
PH	PSM Solvent Weld	UC	Ultra Corr
IG	IPS Gasketed	C2	Corr21
IH	IPS Solvent Weld	P2	Pro21
AD	ADS Corrugated	HG	Heavywall Sewer G
O	Other	HH	Heavywall Sewer SW

- * Outlet gaskets are included on all Drains.
- * Outlets available for Corrugated HDPE, PSM, IPS, C900 and Profile Pipe.
- * Standard grates shipped unless noted.
- * Drains to be made of PVC PSM/PS46.



RISER EXTENSIONS AND GRATES

www.gpk-fargo.com

(For Submittal Information and dimensional data visit our website)

Riser Extensions

Riser Extension Diameter	Part No	Price Per Foot
8" SDR35	RE08LL	33.23
10" SDR35	RE10LL	34.57
12" SDR35	RE12LL	61.15
15" SDR35	RE15LL	67.11
18" SDR35	RE18LL	98.55
24" SDR35	RE24LL	201.75
30" SDR35	RE30LL	444.05

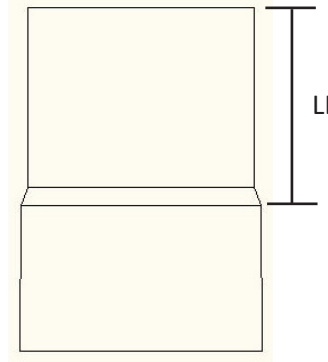

LL

Denotes lay length. Please fill in the desired lay length for LL.
Ex. For a 12" diameter riser with a 24" lay length, the part number would be RE1224



Waste Water Access Chambers

WasteWater Access Chambers

Product Description	Outlet Sizes	Part No. Flat Bottom	List Price Flat Bottom	Part No. With Invert	List Price With Invert
8" Access Chamber	4"-8"	WC08XXF	390.30	WC08XXI	494.38
10" Access Chamber	4"-10"	WC10XXF	514.93	WC10XXI	669.69
12" Access Chamber	4"-12"	WC12XXF	666.90	WC12XXI	980.57
15" Access Chamber	4"-15"	WC15XXF	964.12	WC15XXI	1,442.08
18" Access Chamber	4"-18"	WC18XXF	1,054.51	WC18XXI	1,781.73
21" Access Chamber	4"-21"	WC21XXF	1,248.99	WC21XXI	2,004.27
24" Access Chamber	4"-24"	WC24XXF	1,443.46	WC24XXI	2,226.80
30" Access Chamber	4"-30"	WC30XXF	2,345.98	WC30XXI	3,089.58

* XX Denotes largest outlet size.
 Ex. For a 15" chamber with a flat bottom and the largest outlet being 10", the part number would be WC1510F.



* Outlets available for Corrugated HDPE, PSM, IPS, C900 and Profile Pipe.



Waste Water Access Chamber Order/Quote Form

www.gpk-fargo.com

(For Submittal Information and dimensional data visit our website)

Sale Order _____ PO#: _____ Date: _____ Quote#: _____
(To be Assigned by GPK)

Job Name & Location: _____

Company: _____

Contact: _____

Address: _____

City: _____ State: _____ Zip: _____

Phone: _____ Fax: _____ Email: _____

Signature: _____

Base size _____ (ASTM D3034 or F679 PS46)

Flat or inverted bottom _____

Number of outlets _____

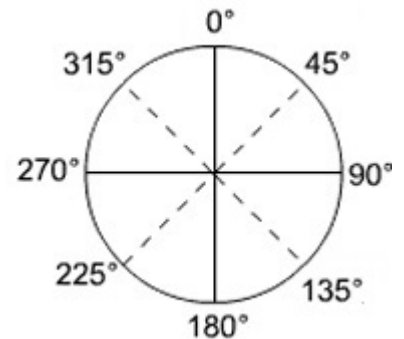

Outlet	Size	Outlet Type	Position Degrees
#1			
#2			
#3			
#4			

Notes (For GPK use.)

WasteWater Access Chambers

Product Description	Outlet Sizes	Socket Depth (SD)	Dimension (B)
8" Access Chamber	4"-8"	4.37	5.58
10" Access Chamber	4"-10"	5.00	5.75
12" Access Chamber	4"-12"	5.00	6.00
15" Access Chamber	4"-15"	5.25	6.75
18" Access Chamber	4"-18"	7.00	7.00
21" Access Chamber	4"-21"	8.50	7.25
24" Access Chamber	4"-24"	9.00	8.24
30" Access Chamber	4"-30"	16.00	8.50

Outlet Types

YG	C900 Gasketed	JM	JM Eagle Corrugated
YH	C900 Solvent Weld	PR	Prinsco Corrugated
PG	PSM Gasketed	UR	Ultra Rib
PH	PSM Solvent Weld	UC	Ultra Corr
IG	IPS Gasketed	C2	Corr21
IH	IPS Solvent Weld	P2	Pro21
AD	ADS Corrugated	HG	Heavywall Sewer G
O	Other	HH	Heavywall Sewer SW

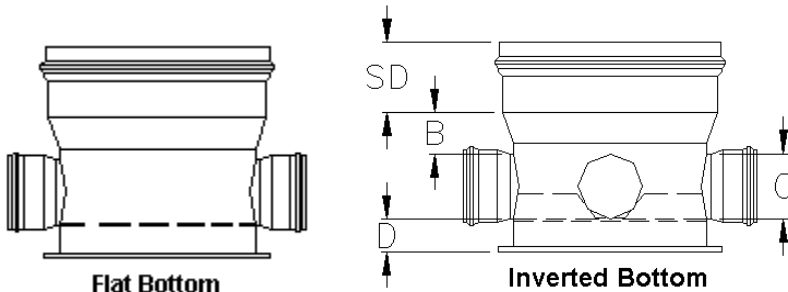

Maximum Invert Depth 2 1/2"
Dimension (C) = Pipe OD of the outlet.
Dimension (D) = Standard length of 3".
Maximum of 2 size on size outlets.

* Outlets available for Corrugated HDPE, PSM, IPS, C900 and Profile Pipe.

1601 43rd Street North • Fargo, ND 58102
Phone: 701-277-3225 Toll Free: 800-437-4670
Fax: 701-277-9286 or 800-822-6989

GPK PRODUCTS, INC.

TERMS AND CONDITIONS OF SALE/SHIPMENT AND USE

ALL ORDERS ARE ACCEPTED AND ALL SALES ARE EXPRESSLY MADE CONDITIONAL ON PURCHASER'S AGREEMENT TO THE TERMS AND CONDITIONS SET FORTH, NOTWITHSTANDING ANY PURCHASE ORDERS OR OFFERS TO PURCHASE CONTAINING DIFFERENT OR ADDITIONAL PROVISIONS. PURCHASER'S ACCEPTANCE OF THE GOODS CONSTITUTES ACCEPTANCE OF THESE TERMS AND CONDITIONS AND ALSO PURCHASER'S AGREEMENT THAT THEY CONTROL OVER ANY TERMS, CORRESPONDENCE OR FORMS SUPPLIED BY PURCHASER AT ANY STAGE OF THE TRANSACTION.

ACCEPTANCE AND CANCELLATION OF ORDERS. Seller may cancel the order, or require full or partial payment in advance of shipment or preparation, if the financial condition of the Purchaser is not satisfactory to the Seller at the time shipment is ready, or at any other time. After acceptance, orders cannot be cancelled by Purchaser without Seller's written consent. All orders are accepted and all sales are made subject only to these Terms and Conditions as a final, complete and exclusive statement of the parties' agreement. No statements, representations, agreements, or changes of any kind or any conflicting terms or conditions incorporated in any writing by Purchaser to Seller are binding on Seller unless specifically agreed to in writing by Seller. Any and all prior statements, representations, and agreements not incorporated herein are excluded and superseded hereby. No course of prior dealings between Seller and Purchaser and no usage of trade shall be used to supplement any term used in this agreement. Acceptance or acquiescence in a course of performance rendered under this agreement shall not be relevant to alter the meaning of this agreement. MODIFICATIONS MUST BE IN WRITING. These Terms and Conditions shall not be modified or rescinded by agreement or conduct or waived unless specifically agreed to in writing by Seller's duly authorized representative.

QUOTATIONS/PRICES/TAXES. After Seller's acceptance of an order, Purchaser's attempted modifications shall not be effective unless accepted in writing by Seller. Acceptance may be conditioned upon Purchaser's acceptance of intervening price changes related to such modifications. The amount of any present and future sales, use, excise, or similar taxes, applicable to the ordered goods shall be added to the Seller's price and paid by the Purchaser, unless the Purchaser timely provides Seller with a tax exemption certificate applicable to Seller.

PRODUCT MODIFICATIONS AND SUBSTITUTIONS. Seller reserves the right to change or modify at any time any product or any materials used in the fabrication of products, or to discontinue the manufacture of any product, without liability with respect thereto.

SHIPMENT AND DELIVERY. Seller reserves the right to make partial shipments. Pro-rata payments become due as partial shipments are made. Seller shall not be liable for any penalty or damages, liquidated or otherwise, for shipment or deliveries which are delayed due to any reason whatsoever. Seller shall not be liable for any loss or damage caused by factors beyond its ability to control, including (without limitation) changes in government regulations or acts of God, Purchaser's acts or omissions, labor shortages, strikes, slowdowns or other combined action or workmen, fires, floods, earthquakes, severe weather, serious accident, epidemics, quarantines, wars, insurrections or riots, acts of civil or military authorities, transportation embargoes, shortages or interruptions, deliveries of components and materials, and delays by Seller's suppliers. Claims for shortages or non-conforming shipments must be made in writing and sent to Seller immediately upon Purchaser's receipt of the shipment. Failure to give such notice shall be deemed unqualified acceptance and a waiver by the Purchaser of any claim with respect to the Shipment.

DAMAGED OR LOST SHIPMENTS. Goods are shipped F.O.B. shipping point only. When goods have been delivered to a carrier for shipment, the risk of loss passes to Purchaser and Seller's responsibility for delivery ends, but Seller agrees to furnish duplicate bills of lading and otherwise render reasonable assistance in making claims for damages against the carrier. Shipment should be examined carefully before being accepted from the carrier. Seller assumes no responsibility for damage after having received "in good order" receipts from a carrier at shipping point and all loss, damage and delay in transit are at the risk of the Purchaser.

RETURNS. Unless its permission has been first obtained, Seller will not accept goods for return or credit, other than for claimed warranty. Risk of loss for returned goods will remain with Purchaser and Purchaser shall reimburse Seller for any cost it incurs in connection with the shipment and return of the goods. Non stock products fabricated to order are not returnable under any circumstances except for approved warranty claim.

TERMS IN EVENT OF NON-PAYMENT. Interest at the maximum legal rate established from time to time, or 18% per year, whichever is lower, shall be charged on overdue accounts. If an invoice is not paid when due, or it becomes necessary for Seller to enforce any of these terms and conditions, Purchaser agrees to pay all costs of the collection, or enforcement or both, including attorney's fees, whether incurred in or out of court, or appeal, in arbitration, in a bankruptcy proceeding, or in any insolvency proceedings.

PENALTY CLAUSES. Seller assumes no liability arising from penalty or liquidated damage clauses of any kind, written or implied, unless specifically approved in writing by Seller's duly authorized representative.

LIMITED WARRANTY/SOLE REMEDY. Seller warrants that its goods shall conform to the applicable CSA or ASTM standards and shall be free from defect in material or workmanship for one year. PVC goods are warranted only for use in accordance with ASTM D-2321 and Unibell PVC Pipe Association Recommended Practices for Installation of PVC Sewer Pipe or other applicable installation standard. Seller will, at its option, repair, replace or issue credit for the purchase price of any goods proven to be non-conforming. Repair or replacement of the goods as described, or return for credit at Seller's option, shall be Purchaser's sole and exclusive remedy for any defect. SELLER'S OBLIGATION IS LIMITED TO THE PURCHASE PRICE OF THE GOODS AND COST OF TRANSPORT.

In the Event the Goods Sold to Purchaser Fail to Conform to the Limited Warranty Referred to Herein, Purchaser must Give Seller Written Notice of Such Nonconformance Within 30 Days of the Time of Discovery of the Defect or the Time When the Defect Should Have Been Discovered, and Within One Year of Receipt of the Goods, or Purchaser Waives Any Right with Respect to the Goods. WITHIN A REASONABLE TIME AFTER WRITTEN NOTICE, AND PURCHASER'S RETURN OF THE DEFECTIVE GOODS TO SELLER, SELLER WILL REPLACE THE DEFECTIVE GOODS OR, IN SELLER'S SOLE DISCRETION, REFUND THE PURCHASE PRICE OF SUCH PORTION OF THE GOODS AS ARE RENDERED UNUSABLE AS A RESULT OF SUCH DEFECT. PURCHASER AGREES THAT THIS IS THE SOLE AND EXCLUSIVE REMEDY OF THE PURCHASER WITH RESPECT TO THE GOODS. SELLER'S ENTIRE LIABILITY ON ANY CLAIM ARISING OUT OF THE SALE OF GOODS OR ITS REPLACEMENT OF DEFECTIVE GOODS, WHETHER IN CONTRACT, WARRANTY, TORT OR OTHERWISE, SHALL BE LIMITED TO THE PURCHASE PRICE OF THE GOODS THAT ARE PROVEN DEFECTIVE AND COST OF TRANSPORT. THIS WARRANTY DOES NOT EXTEND TO, AND IS VOIDED BY, GOODS DAMAGED OR FAILED BECAUSE OF, OR BY USE WITH, MATERIALS OR SUPPLIES OR METHODS NOT APPROVED BY GPK PRODUCTS, INC. OR ASTM D-2321 OR OTHER APPLICABLE INSTALLATION STANDARD; MISUSE; ABUSE; ACCIDENT DAMAGE IN TRANSIT; IMPROPER HANDLING OR INSTALLATION NOT IN ACCORDANCE WITH RECOMMENDED PRACTICES; OR THEIR CONSEQUENCES.

EXCLUSIONS OF WARRANTY AND LIMITATION OF LIABILITY AND REMEDIES. SELLER MAKES NO WARRANTY OTHER THAN THE ABOVE LIMITED SOLE AND EXCLUSIVE WARRANTY. THIS LIMITED WARRANTY AND REMEDY IS EXPRESSLY IN LIEU OF ANY AND ALL OTHER EXPRESS OR IMPLIED WARRANTIES, INCLUDING ANY IMPLIED WARRANTY OF MERCHANTABILITY OR FITNESS FOR A PARTICULAR PURPOSE. THE LIMITED WARRANTY CONSTITUTES THE ONLY WARRANTY MADE WITH RESPECT TO THE GOODS. ALL OTHER WARRANTIES AND OBLIGATIONS ARE EXCLUDED.

SELLER SHALL NOT BE LIABLE FOR ANY DAMAGES, DIRECT, INCIDENTAL, SPECIAL, INDIRECT OR CONSEQUENTIAL, WHETHER RESULTING FROM SELLER'S NEGLIGENCE OR OTHERWISE, ARISING OUT OF, IN CONNECTION WITH, OR RESULTING FROM THE GOODS SOLD TO THE PURCHASER, NOR FOR ANY CLAIMS, ACTIONS, SUITS AND PROCEEDINGS WHICH MAY BE INSTITUTED IN RESPECT TO THE FOREGOING, INCLUDING THOSE MADE BY SUBSEQUENT OWNERS AND USERS OF THE GOODS, NOR FOR STRICT LIABILITY OR OTHER TORT, NOR FOR LOSS REVENUES OR EARNINGS, LOST PROFITS, LOST OPPORTUNITIES, COSTS OR DELAYS, LOST GOOD WILL OR REPUTATION, OR PUNITIVE OR EXEMPLARY DAMAGES. IN THE EVENT IT IS FOUND THAT THE REMEDIES PROVIDED BY THIS CONTRACT FAIL OF THEIR ESSENTIAL PURPOSE, SELLER'S LIABILITY SHALL NONETHELESS BE LIMITED TO THE REFUND OF WHATEVER PORTION OF THE PURCHASE PRICE THAT HAS BEEN PAID, AND TRANSPORTION COSTS.

CONDITIONS OF RESALE/SUBSEQUENT PURCHASES. These Terms and Conditions shall be binding upon Purchaser and all subsequent owners and users of these goods. The goods are sold subject to the condition that they shall not be resold or otherwise conveyed without similar conditions, including that this condition be imposed on the subsequent purchaser, or transferee.

SEVERABILITY. The invalidity of all, or a part of any of the Terms and Conditions set forth herein shall not invalidate the remainder of such Terms and Conditions. **CHOICE OF LAW AND BINDING ARBITRATION.** These Terms and Conditions shall be construed and governed by the laws of the State of North Dakota. All disputes and controversies hereunder, including action to collect, shall be submitted to and settled by binding arbitration in Cass County, North Dakota under the rules of the American Arbitration Association; and judgement may be rendered upon the award by the District Court in North Dakota. Any legal action shall be venued in Cass County District Court, Fargo, North Dakota.

***WE CUSTOM
MANUFACTURE OUR
DRAINAGE PRODUCTS TO
YOUR SPECIFICATIONS!***

***We are in business to take
care of you,
Our Customers!***

***PHONE: 800-437-4670
FAX: 800-822-6989***

